

# **ICE CUBES MAKERS Range**

## **SPRAY Technology**



## CONTENTS

### **Introduction**

Warnings.....	3
Description – Operating Principles.....	5
Operating principle following the electric diagram.....	6

### **Specifications**

Diagrams of connections and dimensions.....	9
Consumptions, weights, packaged dimensions and volume.....	10
Technical Data .....	11
Production Figures .....	12

### **Reception of the machine**

Packaging - Housing – Specifications plate .....	16
--	----

### **Installation**

Required conditions for placement of unit - Water and drainage.....	17
Connection to water mains (water condensing ) – Connection to drain – Electrical connection ....	18

### **Starting**

Preliminary checking.....	19
Starting .....	20

### **Adjustments**

Fan pressostat (air condensing).....	21
Security pressostat.....	22

### **Maintenance and cleaning instructions and procedures**

Maintenance chart.....	23
Water condenser – Air condenser - Evaporator / Water tray.....	24
Storage bin – Housing - Pipes and nozzles.....	25
Water Filter – Water leaks control .....	26

<b>Special advises of use R404A Refrigerant.....</b>	<b>26</b>
--	-----------

<b>Troubleshooting .....</b>	<b>27</b>
------------------------------	-----------

## **INTRODUCTION**

Thank you for choosing **ITV's NG DP** Ice Cube Maker.

You have purchased one of the most reliable ice-making products on the market today. Carefully read the instructions contained in this manual since they provide important information relative to safety during installation, use, and maintenance.

## **WARNINGS**

- This appliance should be installed by approved Technical Service Personnel.
- This plug should be accessible at all times.
- To reduce the risk of electrical shock, **ALWAYS** disconnect the machine **BEFORE** cleaning or maintaining the equipment. Do not attempt to install, service, or modify this machine.
- Improper use by other than specially trained technicians is extremely dangerous and may result in a fire or electric shock.
- This product has not been designed for any uses other than producing ice cubes with drinking water.
- It is extremely dangerous to modify or try to modify this appliance. Besides it would automatically cancel the warranty totally.
- This appliance is not intended for use (including children) with reduced physical, sensory or mental capabilities, or lack of experience and knowledge, unless they have been given supervision or instruction concerning use of the appliance by a person responsible for their safety.
- Children should be supervised to ensure that they do not play with the appliance.
- This machine should not be placed outdoors or exposed to rain.
- Connect to drinking water mains.
- Connect only with the powerd supply cord supplied with the machine.
- This appliance is not intended to be connected to a fix canalization.
- Please follow the instructions given by the manufacturer in order to guarantee the efficiency of this machine and a proper operation. **THE CLEANING AND MAINTENANCE** should be carried out by trained personnel in most of the cases.

**IMPORTANT:**

- Do not attempt to service this machine yourself. Improper use by other than specially trained technicians is extremely dangerous and may cause severe damage to the unit. In case of breakdown contact an authorised distributor. We strongly recommend using only original replacement parts.

- Waste and other material should be disposed in accordance to local regulations and procedures for waste disposal.

**CLEANING AND MAINTENANCE OPERATIONS ARE NOT COVERED BY THE WARRANTY AND WILL BE INVOICED BY THE INSTALLER..**

## **DESCRIPTION**

Main features:

- Stainless steel body AISI 304 and chapa galvanizada.
- Anti-blocking spray nozzles.
- Pump without seals.
- High pressure safety pressostats even in air-cooled machine.
- Large condensers (work well at high ambient temperatures; and reduce cooling water consumption in water-cooled machines).
- TRANSPARENT CUBES with most of the water mains.

ALFA CUBE

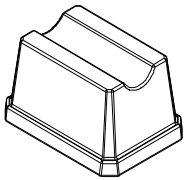

GALA CUBE

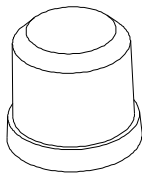

DELTA CUBE

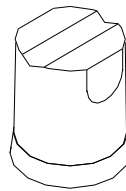

SUPER STAR CUBE

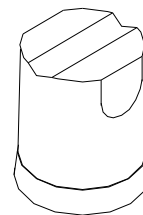

## **OPERATING PRINCIPLE**

WHEN SWITCHING ON THE MACHINE FOR THE FIRST TIME, THE MACHINE SHOULD BE PLACED ON THE DEFROSTING STAGE. To do so, turn the wheels on the timer until the microswitches are depressed.

- At this moment, the compressor is working; the water inlet valve and hot gas inlet valve are both open. The water bin fills with water, any excess is lost via the maximum level overflow.

- After a period of time controlled by the timer the hot gas valve and water inlet valve are closed. The pump then sends water to the evaporator where the ices cubes are gradually formed. The evaporation temperature slowly descends until it reaches a point where the cycle thermostat is connected and starts the timer. Once this time has elapsed, the defrosting stage (3-4 minutes) begins. The pump is off and the hot gas and water valves are open. Some water is sent to the top of the evaporator to help the cubes unstick.

- Once the defrosting stage is over, the cycle begins again, and so it continues until the bin is full of ice, and contact between the bin thermostat situated at the top of the bin and the ice will stop the machine. The bin thermostat will never stop the machine in mid-cycle.

## **OPERATING PRINCIPLE FOLLOWING THE ELECTRIC DIAGRAM (TIMER ON DEFROST - MICROSWITCHES DEPRESSED).**

- The ITV model NG has two switches:

1<sup>st</sup> In the frontal side of the machine (with led). This turns the machine on or off when we press it.

2<sup>nd</sup> The second switch is located in the electrical panel. This one stops the condensing unit, but keeps the hydraulic part in operation and allows to do the cleaning of the machine (except in NDP20 model).

- Current reaches the machine via the line connecting the blue (1) and brown (2) terminals. The brown wire connects the compressor and timer motor. The blue wire connects bin thermostat T1 which closes the circuit with 2. A different blue wire goes to 2 on terminal G1 which at this moment is connecting 1 and 4.

- A red wire connects bin thermostat T1 and micros G1 and G2 which close the circuit with 4 and provide current via G1 to the timer G.

- At this point the following are connected:

- ✓ COMPRESSOR (S)
- ✓ WATER INLET VALVE (P)
- ✓ HOT GAS VALVE (Q)
- ✓ TIMER MOTOR (G)

- Since the motor of the timer (G) is working, during 1÷3 minutes the roller of micro of the second water inlet coil (cleaning valve drive) is depressed until the pins release the micro, closing this valve..

- After 2 to 4 minutes micros G1 and G2 will open and close circuits 1-2.

- Via terminal 2 on micro G2, current reaches the pump. Circuit 4 on micro G2 which provides current to the hot gas valve (Q) and water inlet valve (P) will be interrupted. Since the thermostat is between 1 and 3 the timer will receive no current. The compressor continues switched on.

- Air-cooled machines have a fan (R) which is controlled by the pressostat (F).
- In water-cooled models without pressostatic valve, pressostat (J) opens and closes the condenser electrovalve (K).
- Evaporator temperature decreases until the cycle thermostat (T2) set point is reached, at this temperature circuit 1-2 will be closed and timer motor (G) will switch on.
- Once the cycle is over, the pins on the timer wheels will force the micros to change circuits, stopping the pump and opening the hot gas valve and water valve. The combined effect of hot gas and water sprayed on the top of the evaporator will release the ice cubes and change the position of the cycle thermostat (T2).
- The ice production and defrosting cycle will continue until the ice storage bin is full, at which point cycle thermostat (T1) will disconnect the machine, but never during a cycle, but at the beginning of the defrosting stage, since during the production cycle, current will reach the pump via terminals 1-2 of micro G1.
  
- The machine will remain disconnected until the level of ice in the bin drops below the thermostat because of ice consumption. At this point the bin thermostat T1 changes and the machine will start a new production cycle automatically.

PRACTICO/PRACTICAL/PRAKTISCH/PRACTIQUE

TEORICO/THEORATICAL/THEORETISCH/THEORIQUE/FUNZIONALE

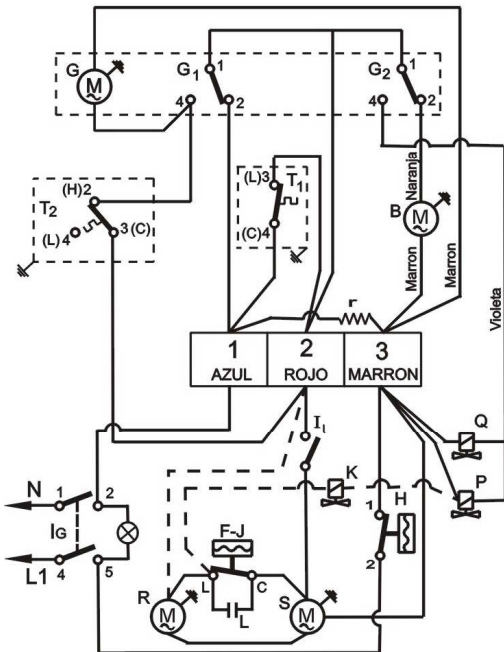

VALIDO DESDE EL 03-06-08  
ES-16-1

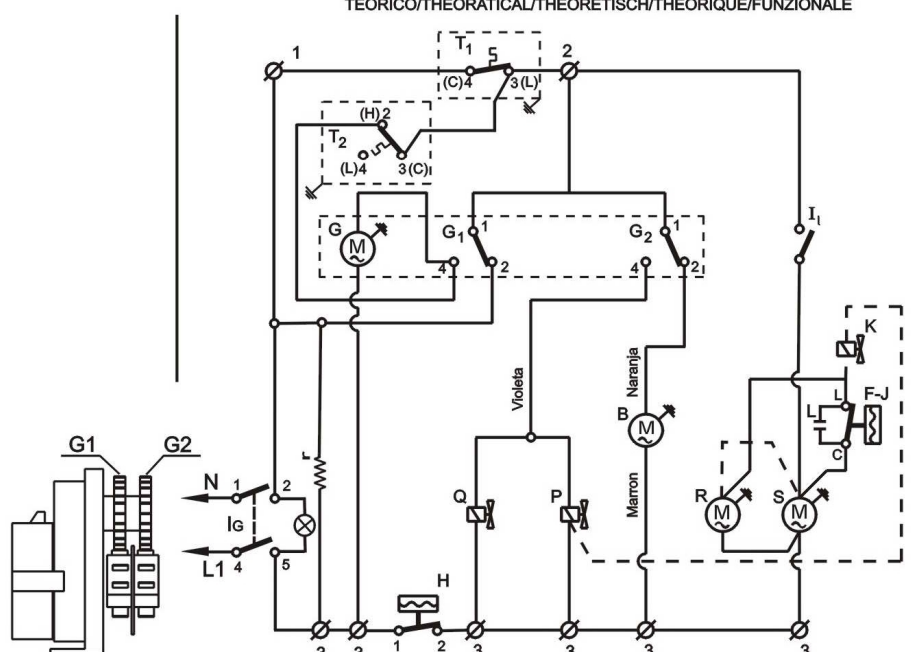

PROGRAMADOR

**COMPONENTES**

- B Motor bomba
- F Presostato ventil. (solo aire)
- G Motor programador
- G1 Circuito segurid. programador
- G2 Circuito programador
- H Presostato seguridad
- J Presostato condens. (solo agua)
- K Electroval. condens.(solo agua)
- P Electroval. de agua
- Q Electroval. gas caliente
- R Motor ventilador
- S Compresor
- T1 Termostato almacen
- T2 Termostato ciclo
- L Condensador filtro
- r Resistencia 20W
- Ig Interruptor general
- I1 Interruptor de limpieza
- para cond. agua

**COMPONENTS**

- B Motor pump
- F Fan pressostat (air)
- G Cam timer motor
- G1 Circuit safety timer
- G2 Circuit timer
- H Safety pressostat
- J Condens. pressostat (water)
- K Condens. electrov. (water)
- P Water electrovalve
- Q Hot gas electrovalve
- R Fan motor
- S Compressor
- T1 Stock thermostat
- T2 Cycle thermostat
- L Filter condenser
- r Resistance
- Ig Switch on/off
- I1 Cleaning switch
- for water cond.

**BESTANDTEILE**

- B Motorpumpe
- F Ventilatorpresostat (nur Luft)
- G Motorprogrammierer
- G1 Sicherheitsstromkreis des Program.
- G2 Stromkreis des Program.
- H Sicherheitspresostat
- J Kondensatorpresostat (nur Wasser)
- K Elektrov. des Kondens. (nur Wasser)
- P Elektrov. für das Wasser
- Q Elektrov. für warmes Gas
- R Motorventilator
- S Kompressor
- T1 Lagerthermostat
- T2 Zyklusthermostat
- L Kondensatorfilter
- r Widerstand
- Ig Schalter An/Aus
- I1 Reinigungsschalter
- Für Wasser gekühlt

**COMPONENTI**

- B Motore pompa acqua
- F Pressostato ventola (aria)
- G Motore timer
- G1 Sicurezza timer
- G2 Timer
- H Pressostato sicurezza
- J Pressostato sicurezza (acqua)
- K Electroval. condensatore(acqua)
- P Electroval. acqua
- Q Electroval. gas caldo
- R Motoventilatore
- S Compresore
- T1 Termostato contenitore
- T2 Termostato ciclo
- L Condensatore radio disturbi
- r Resistenza
- Ig Interruttore generale
- I1 Commutatore di pulizia
- per cond. acqua

**COMPOSANTS**

- B Moteur pompe
- F Presostat ventilation (air)
- G Moteur programmeur
- G1 Programmeur sécurité circuit
- G2 Circuit programmeur
- H Presostat sécurité
- J Presostat condensation (eau)
- K Electroval. condensation (eau)
- P Electroval. eau
- Q Electroval. gaz chaud
- R Moteur ventilateur
- S Compresseur
- T1 Thermostat stock
- T2 Thermostat cycle
- L Condensateur filtre
- r Resistance
- Ig Interrupteur general
- I1 Interrupteur nettoyage
- pour cond. eau



# SPECIFICATIONS

Models:

NDP 20

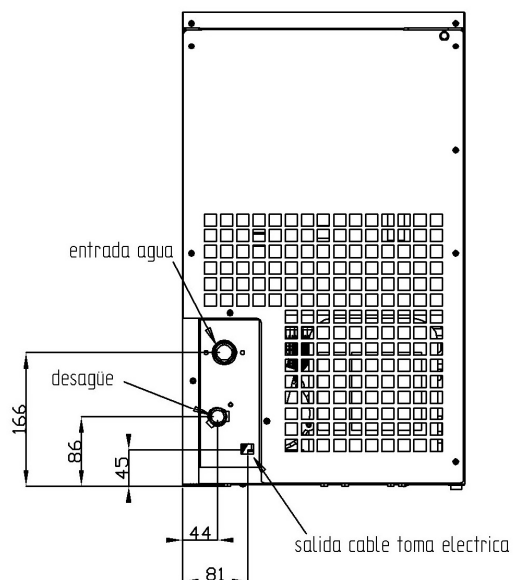
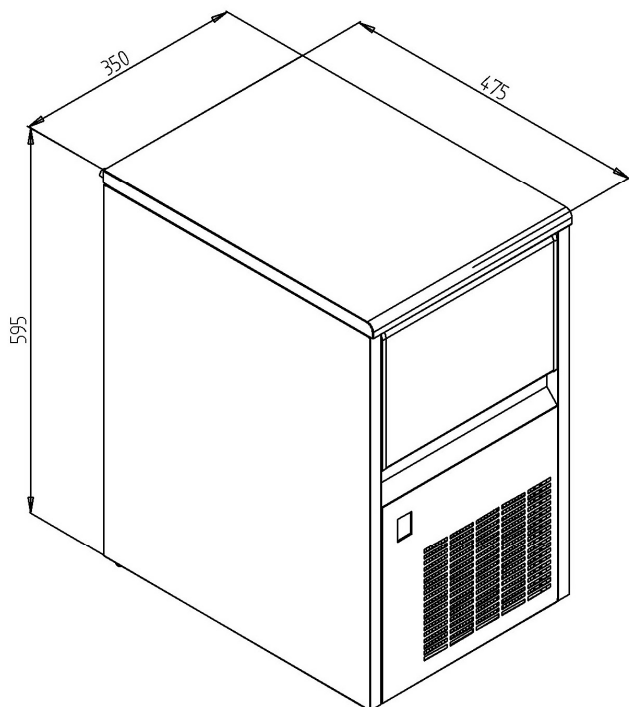

NG DP 30 - 150.

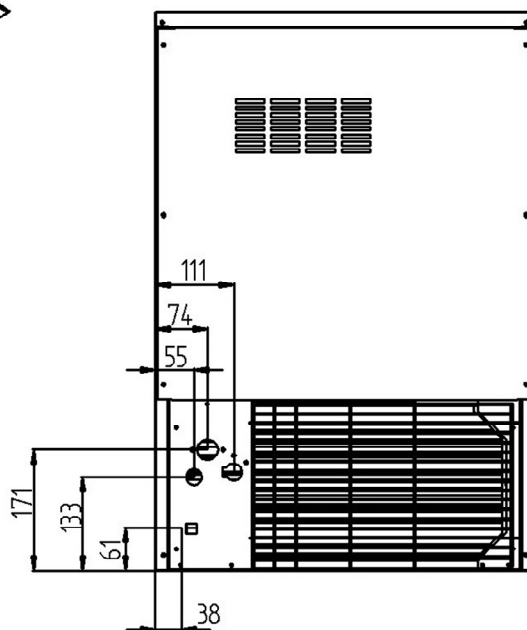
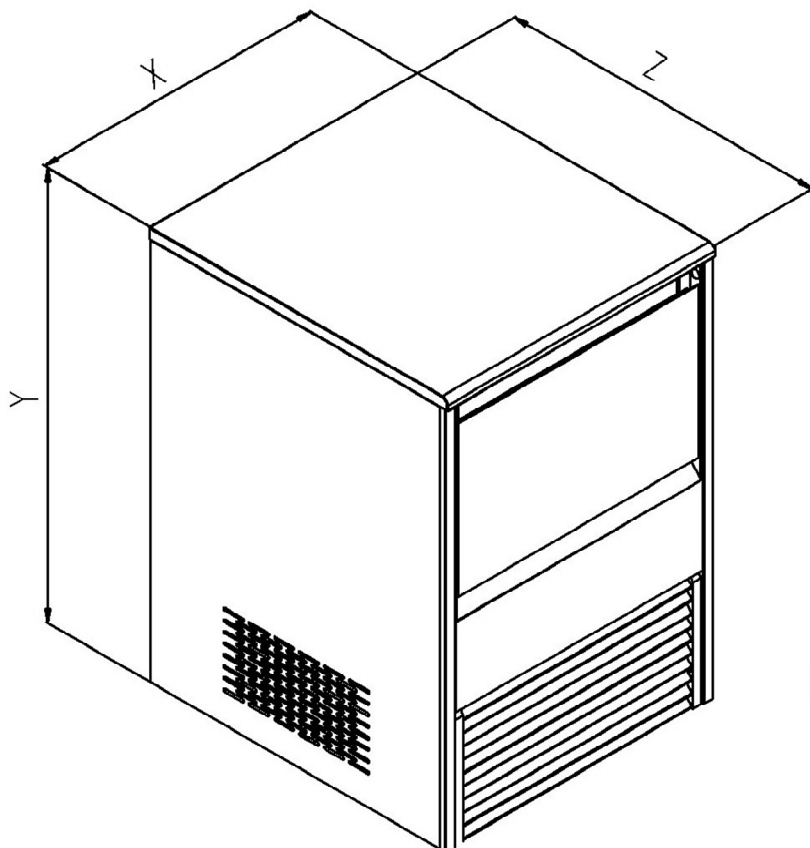

# NG MDP 150

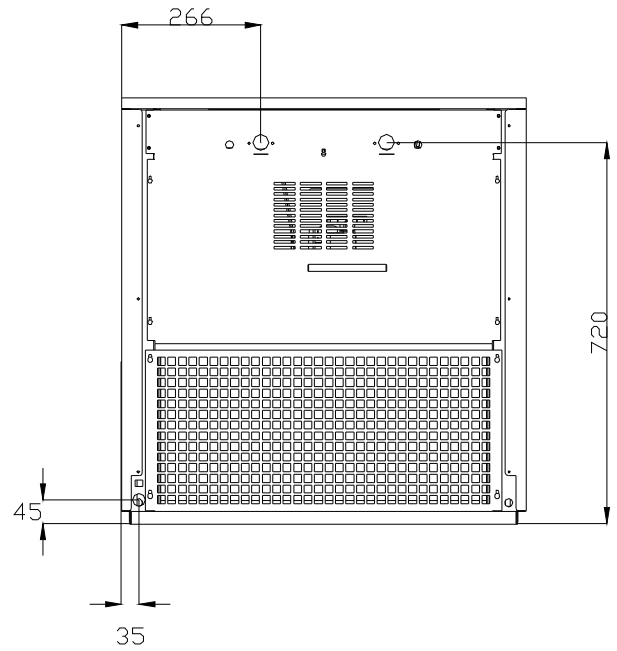
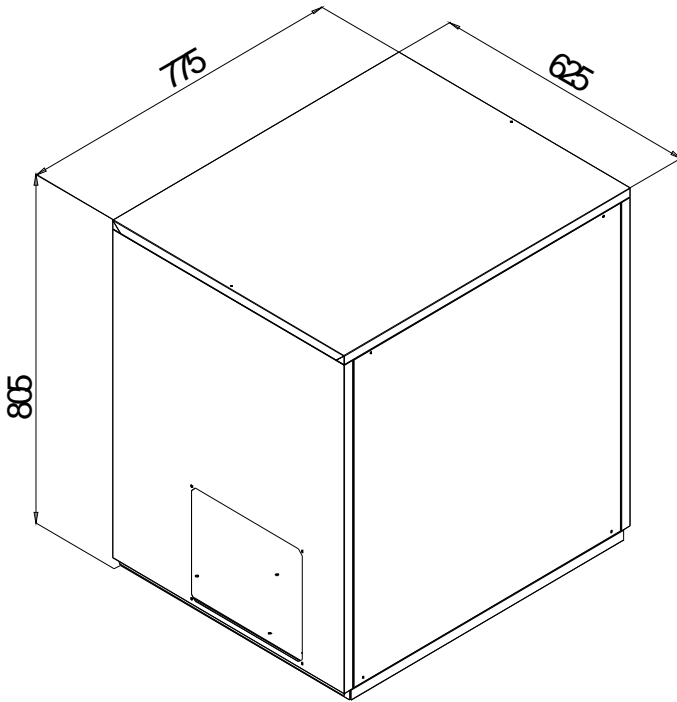

MODEL	CONSUMP. WATER COND.. L/HOUR (1)	CONSUMP. WATER PROD. L/HOUR (1)	CONSUMP. TOTAL WATER L/HOUR (1)	NET WEIGHT (KG)	DIMENSIONS MACHINE	DIMENSIONS PACKAGING X*Y*Z	GROSS WEIGHT (KG)	VOLUME (M <sup>3</sup> )
NDP 20 A		5.1	<b>5.1</b>	36	350x474x592	420x540x725	35	0.20
NDP 20 W	18	5.1	<b>23.1</b>	36	350x474x592	420x540x725	35	0.20
VG 30 A		14	<b>14</b>	39	405x560x770	485x610x790	45	
VG 30W	20	14	<b>34</b>	39	405x560x770	485x610x790	45	
VG 35 A		14	<b>14</b>	42	465x595x795	525x645x920	50	
VG 35 W	20	14	<b>34</b>	42	465x595x795	525x645x920	50	
VG DP 45 A		18.8	<b>18.8</b>	45	465x595x795	525x645x920	53	
VG DP 45 W	24	18.8	<b>42.8</b>	45	465x595x795	525x645x920	53	
VG DP 60 A		28.8	<b>28.8</b>	48	535x595x795	595x645x920	67	0.40
VG DP 60 W	30	28.8	<b>58.8</b>	48	535x595x795	595x645x920	67	0.40
VG DP 80 A		14.6	<b>10.6</b>	58	715x595x945	780x670x1055	78	0.57
VG DP 80 W	54	14.6	<b>68.6</b>	58	715x595x945	780x670x1055	78	0.57
VG DP 110 A		17.2	<b>17.2</b>	89	715x700x1050	780x780x1070	100	
VG DP 110 W	59	17.2	<b>76.2</b>	89	715x700x1050	780x780x1070	100	
VG DP 150 A		22.4	<b>22.4</b>	95	860x700x1050	925x780x1070	105	
VG DP 150 W	62	22.4	<b>84.4</b>	95	860x700x1050	925x780x1070	105	
VG MDP 150 A		22,4	22,4	70	775x625x805	820x700x825	80	
VG MDP 150 W	62	22,4	84,4	70	775x625x805	820x700x825	80	

MODEL	REFRIGER. CHARGE  (GR)	HIGH PRESSURE		LOW PRESSURE	TOTAL INTENST. AMPS	FUSE SECURITY  (TO INSTALL)	POWER COMPRESSOR	POWER ABS
		MIN.	MAX.	AVERAGE		(A)	(W)	(W)
NDP 20 A	345			2'5 bar	2	10	1/5	355
NDP 20 W	285				2		1/5	355
NG 30 A	320				2		1/4	423
NG 30 W	300				2		1/4	423
NG 35 A	360				2		1/4	540
NG 35 W	310				2		1/4	540
NG 45 A	420				3		3/8	550
NG 45 W	365				3		3/8	550
NG DP 60 A	420	15'5 bar	18 bar		3.5		3/8	650
NG DP 60 W	350				3.5		3/8	650
NG DP 80 A	470				3		1/2	780
NG DP 80 W	355				3		1/2	780
NG 110 A	1000				4		7/8	1150
NG 110 W	1000				4		7/8	1150
NG 150 A	1000				4		13/8	1350
NG 150 W	1000				4		13/8	1350
MDP 150 A	1200				5.5		13/8	1500
MDP 150 W	1200				13/8	1500		

(1) Data obtained at room temperature (20°C), water introduced at 15°C; water quality = 500ppm

(2) Maximum consumption obtained at room temperature=43°C, according to UNE climate classification Class T (TROPICALISED)

**NOTE:** Expansion controlled by capillary except in modulars models where it is controlled by means of an expansion valve.

**PRODUCTION CHARTS (Kg/Day)**

**NDP20**

<b>Tw/Tr</b>	<b>45</b>	<b>40</b>	<b>35</b>	<b>30</b>	<b>25</b>	<b>20</b>	<b>15</b>	<b>10</b>
<b>35</b>	8	10	13	14	16	17	17	17
<b>30</b>	12	15	17	19	20	21	21	21
<b>25</b>	15	18	20	22	24	24	25	25
<b>20</b>	19	21	24	25	27	28	28	28
<b>15</b>	22	24	27	28	30	20	31	31
<b>10</b>	24	27	29	31	32	33	33	33
<b>5</b>	26	29	31	33	34	35	35	35

**NG 30**

<b>Tw/Tr</b>	<b>45</b>	<b>40</b>	<b>35</b>	<b>30</b>	<b>25</b>	<b>20</b>	<b>15</b>	<b>10</b>
<b>35</b>	12	16	19	22	24	25	26	26
<b>30</b>	18	22	25	28	30	31	32	32
<b>25</b>	23	28	31	34	36	37	38	37
<b>20</b>	28	32	36	38	40	42	42	42
<b>15</b>	33	37	40	43	45	30	47	47
<b>10</b>	36	40	44	46	48	50	50	50
<b>5</b>	39,6	43	47	49	51	53	53	53

**NG 35**

<b>Tw/Tr</b>	<b>45</b>	<b>40</b>	<b>35</b>	<b>30</b>	<b>25</b>	<b>20</b>	<b>15</b>	<b>10</b>
<b>35</b>	14	19	22	26	28	29	30	30
<b>30</b>	21	26	30	33	35	37	37	37
<b>25</b>	27	32	36	39	42	43	44	44
<b>20</b>	33	38	42	45	47	49	50	50
<b>15</b>	38	43	47	50	52	35	55	54
<b>10</b>	42	47	51	54	56	58	59	59
<b>5</b>	46	51	54	58	60	61	62	62

**NG 45**

<b>Tw/Tr</b>	<b>45</b>	<b>40</b>	<b>35</b>	<b>30</b>	<b>25</b>	<b>20</b>	<b>15</b>	<b>10</b>
<b>35</b>	18,3	24,4	29,5	33,5	36,5	38,5	39,4	39,4
<b>30</b>	27,5	33,6	38,7	42,8	45,8	47,7	48,7	48,6
<b>25</b>	35,8	41,9	47	51,1	54,1	56	57	56,9
<b>20</b>	43,2	49,3	54,3	58,4	61,4	63,4	64,3	64,2
<b>15</b>	49,5	55,7	60,7	64,8	67,8	45	70,7	70,6
<b>10</b>	55	61,1	66,1	70,2	73,2	75,2	76,1	76
<b>5</b>	59,4	65,5	70,6	74,6	77,7	79,6	80,6	80,5

**NG 60**

<b>Tw/Tr</b>	<b>45</b>	<b>40</b>	<b>35</b>	<b>30</b>	<b>25</b>	<b>20</b>	<b>15</b>	<b>10</b>
<b>35</b>	24,4	32,5	39,3	44,7	48,7	51,3	52,6	52,5
<b>30</b>	36,7	44,9	51,6	57	61	63,7	64,9	64,8
<b>25</b>	47,8	55,9	62,7	68,1	72,1	74,7	76	75,9
<b>20</b>	57,6	65,7	72,5	77,8	81,9	84,5	85,8	85,6
<b>15</b>	66,1	74,2	81	86,4	90,4	60	94,3	94,2
<b>10</b>	73,3	81,4	88,2	93,6	97,6	100,2	101,5	101,4
<b>5</b>	79,2	87,4	94,1	99,5	103,5	106,2	107,4	107,3

**NG 80**

<b>Tw/Tr</b>	<b>45</b>	<b>40</b>	<b>35</b>	<b>30</b>	<b>25</b>	<b>20</b>	<b>15</b>	<b>10</b>
<b>35</b>	32	43	52	59	64	68	70	70
<b>30</b>	49	59	68	76	81	84	86	86
<b>25</b>	63	74	83	90	96	99	101	101
<b>20</b>	76	87	96	103	109	112	114	114
<b>15</b>	88	98	108	115	120	80	125	125
<b>10</b>	97	108	117	124	130	133	135	135
<b>5</b>	105	116	125	132	138	141	143	143

## NG 110

Tw/Tr	45	40	35	30	25	20	15	10
35	44	59	72	81	89	94	96	96
30	67	82	94	104	111	116	119	118
25	87	102	114	124	132	137	139	139
20	105	120	132	142	150	154	157	157
15	121	136	148	158	165	110	172	172
10	134	149	161	171	178	183	186	185
5	145	160	172	182	189	194	197	196

## NG 150

Tw/Tr	45	40	35	30	25	20	15	10
35	61	81	98	111	121	128	131	131
30	91	112	129	142	152	156	162	162
25	119	139	156	170	180	186	190	189
20	143	164	181	194	204	211	214	214
15	165	185	202	215	225	150	235	235
10	183	203	220	233	244	250	253	253
5	198	218	235	248	258	265	268	268

## DELIVERY & UNPACKING

Upon receipt, thoroughly inspect the packing container. If there appears to be damage to the container contact the shipper immediately.

Unpack the unit in presence of the forwarder noting any damage on the delivery note or CMR or in an additional document. ITV packing bears the “**Green Point**” on all models since January 1st 1998 according to the European Directives on management of Packaging and Waste Disposal.ITV.

Be sure to include model name and serial number on all claims. Serial number is located in the following three places:

### Packing

There is a label stick onto the cardboard packing bearing this serial number (1).

### Machine body

On the back of the machine (1).

### Rating plate and serial number

Located at the back of the machine (1).

Water cooled machines: check that the drainage hose at the back of the machine is in good condition.

Verify that the instalation kit is inside the bin, and has the following pieces: scoop, 3/4' water hose, two small filters and user

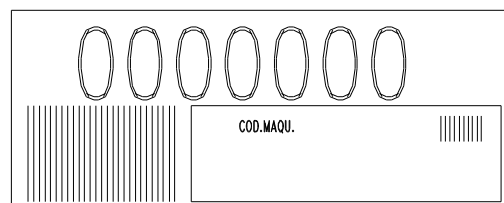
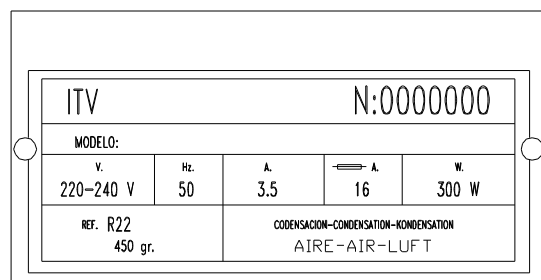

**WARNING: DO NOT LEAVE PACKING MATERIALS (PLASTIC BAGS, CARDBOARD**



**BOXES, ETC.) IN REACH OF CHILDREN.**

## **INSTALLATION**

### ***Required conditions for placement of unit***

#### **IMPORTANT:**

The NG machines are intended to work at room temperature between 5°C and 43°C and with water temperature between 5°C and 35°C.

Difficulties during harvest cycle can appear below these minimum temperatures. Above the maximum temperatures the life of the compressor becomes shorter and the production decreases considerably.

#### **IMPORTANT:**

The new box-type frame in NG models allows a better ventilation in the air-cooled machines, due to the fact that the condensers are placed in oblique position in the front part of the machine.

The machines will work properly even if they are located in places with little ventilation at the rear and lateral sides. The air is expelled by the front grill.

Bear in mind the previous remarks if the premises where the machine is located is very dusty or smoky

The floor on which the machine will be placed should be solid and as leveled as possible.

### ***Water and drainage***

Water quality influences on ice hardness, flavour, and quality as well as condenser life.

Keep in mind the following points:

#### **a) WATER IMPURITIES:**

Major impurities are eliminated by filters provided. Filters should be cleaned regularly depending on purity of water. For minor impurities we recommend installing a 5-micron filter (Provided with the unit.: Part # ITV 7499).

**b) WATER WITH MORE THAN 1000 PPM:**

Ice will be less hard and tend to adhere. Cubes with white spots may appear. Lime deposits may impede proper functioning. In water cooled models, condenser obstruction is likely. Installation of a high quality water softener is recommended. Lime deposits can be avoided with the installation of our polyphosphates filter. (Part # ITV 7500).

**c) CHLORINATED WATER:**

Chlorine taste can be avoided by installing a carbon filter (Part # ITV 7509).

(NOTE: You may encounter water with all aforementioned properties.)

**d) HIGHT-PURITY WATER:**

Up to 10% reduction in overall production may occur.

***Connecting Unit To Water Source***

- Use 1.3 m. flexible tube (with the two filter joints provided) provided. NOTE: We advise against using faucets with two exits and two keys since they can close the buttock by mistake and so the machine remains without water. This may indicate a false failure.

- Water pressure should be between 0.7 and 6 Bars. (10/85 psi.)

- If water pressure exceeds these values, installation of appropriate corrective units will be necessary.

- It is important that water tubing does not come close to or in contact with any heat sources or heat generated by unit as this could decrease production.

***Connecting Unit To Drain***

- Drain must be located at least 150mm. below machine

- Drain tube must have an inner diameter of 30mm. with a minimum gradient of 3 cm per meter.

***Electrical connection:***

- The Unit is provided with a 1.5 m cord and schucko socket. If the cord is damaged should be replaced by a cord or special assembly supplied by the manufacturer or after-sales service.

- It is strongly recommended to leave a minimum space between the rear side and the wall in order to have an easy access to the plug without risks.

- It is advisable to install a switch and adequate fuses. Nominal voltage and intensity are indicated on rating plate as well as on this manual's technical pages. Voltage fluctuations greater than 10% can cause problems or prevent machine from starting.

- The Line to base of plug must have a minimum section of 2.5 mm<sup>2</sup>.
- Be sure voltage indicated on rating plate corresponds to that of mains supply.

### **IMPORTANT!**

Supply socket must be properly earthed. Be sure to check standard for country where appliance is going to be installed.

### **OPERATION**

#### ***Preliminary Check***

- Is machine levelled?
- Are voltage and frequency of mains supply the same as indicated on rating plate?
- Is drainage system functioning?
- Is air circulation and room temperature adequate? (\*\*Air cooled models)

<b>TEMPERATURE</b>	<b>ROOM</b>	<b>WATER</b>
<b>MAXIMUM</b>	43 C	35°C
<b>MINIMUM</b>	5° C	5°C

- \*\* Is water pressure adequate?

**MINIMUM** 0.7 Bar

**MAXIMUM** 6 Bar

**NOTE:** To install a pressure reducer if water inlet pressure is more than 6 bar.

**ATTENTION:** Check that voltage and mains frequency are the same as in the rating plate.

## **STARTING UP**

Having followed the installation instructions (ventilation, temperature, room conditions, water quality, etc...), proceed as follows:

- 1) Open water faucet. Check for leaks.
- 2) Plug machine into electricity mains supply.
- 3) Switch on the machine (the switch is in the front of the machine).
- 4) Ensure that there are no strange vibrations or scraping sounds.
- 5) Check that the water curtain moves freely.
- 6) Verify that the nozzles send water to the evaporator in the correct direction (uniform fans).
- 7) After 10 minutes, check that the water bin has no leaks on the maximum level overflow.

### **ATTENTION:**

ADVISE THE FINAL USER ON MAINTENANCE PROCEDURES WHICH **ARE NOT INCLUDED IN WARRANTY**, AS WELL AS THOSE BREAKDOWNS CAUSED BY NEGLIGENCE OF PROPER MAINTENANCE PROCEDURES.

## ADJUSTMENTS

### ***Condenser water valve pressostat***

- This pressostat controls high pressure by opening and closing the condenser water valve. Differential is a fixed 1 Bar (14 psi.).

- The valve closes at 15 Bar (214 psi), which is equivalent to a condensation water exit temperature of 38°C. . Below this pressure it will be difficult to unstick the cubes during the defrosting cycle.

- Above this pressure, compressor life and ice production are both reduced.

Pressure can be increased by turning the small screw on the pressostat clockwise. A full turn is equivalent to about 1.5 Bar.

### ***Fan pressostat ( air condensation)***

Pressure Control operates on high pressure by starting and stopping fan. Differential is a fixed (1 Bar or 14 psi.).

Cut-off pressure must be 15 Bar (214 psi). Low pressure values may cause difficulties during harvest cycle. Higher pressure values may shorten compressor life and diminish ice production.

Pressure can be regulated by rotating screw on Pressure Control Valve (clockwise to increase pressure). One full turn is equivalent to about 1.5 Bar.

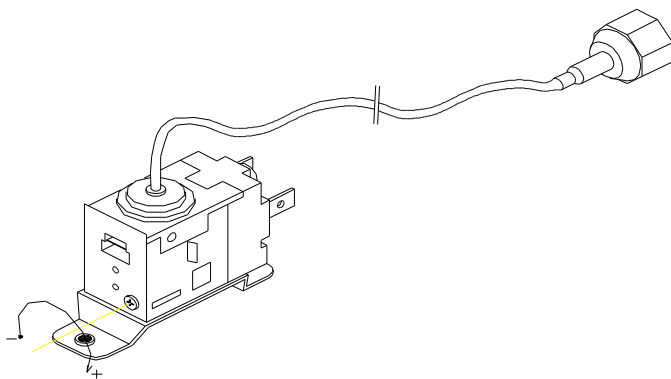

### ***Safety Pressostat***

This safety device trips when discharge pressure is too high. Pressure might exceed the limit when:

- a) Air circulation is not sufficient, room temperature is too high or condenser is dirty (air cooled models).
- b) There is not enough water in the system temperature is too high in water cooled models.

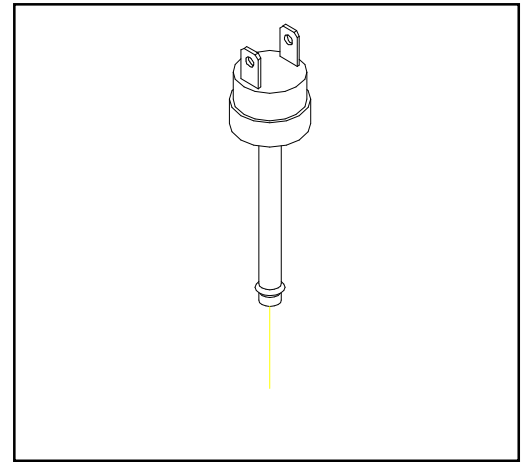

### **HIGH PRESSURE REGULATION (fixed):**

3030-22 Bar (from model 110 part # 2683)

27-21 Bar (380-296 psi.)

## MAINTENANCE AND CLEANING INSTRUCTIONS

**IMPORTANT:** Maintenance and cleaning procedures as well as problems derived from failing to carry them out are not covered by the warranty.

Proper maintenance is essential to obtain favourable ice quality and optimum functioning of unit.

- Frequency depends on water quality and characteristics of room where unit is installed.

**IMPORTANT:** Maintenance/cleaning procedures should take place at least once every six months. If concentration of air pollutants is high, complete procedures on a monthly basis.

### MAINTENANCE TABLE:

PROCEDURE	MONTHLY	QUARTERLY	BIANNUAL	ANNUAL	BIENNIAL	DURANTION
Air condenser cleaning	0000	0000	****	****	****	30 minutes
Water condenser cleaning				####	****	90 minutes
Inyectors cleaning		####	####	****	****	30 minutes
Fabrication head filter cleaning			####	****	****	30 minutes
Water circuit cleaning		####	####	****	****	45 minutes
Sanitary cleaning		####	####	****	****	30 minutes
Water filter cleaning/replacement	####	####	****	****	****	30 minutes
Stock deposit cleaning.	&&&	&&&	&&&	&&&	&&&	--
Unit cleaning	&&&	&&&	&&&	&&&	&&&	--

0000 Depending on room characteristics

#### Depending on water quality

&&& CARRIED OUT BY OWNER

\*\*\*\* **ESSENTIAL**

### MAINTENANCE AND CLEANING PROCEDURES AS WELL AS PROBLEMS DERIVED FROM FAILING TO CARRY THEM OUT ARE NOT COVERED BY THE WARRANTY.

Service personnel will invoice you for travel expenses, time invested and materials required for maintenance and cleaning of unit.



## **MAINTENANCE AND CLEANING PROCEDURES**

**\*\* WARNING:** Unit should always be disconnected during maintenance/cleaning procedures.

### ***Water Condenser***

- 1) Disconnect machine.
- 2) Close water faucet.
- 3) Disconnect water entry/exit from condenser.
- 4) Prepare a solution of 50% phosphoric acid in distilled water.
- 5) Distribute solution through condenser. (Solution is more effective at 35°-40°C).

**WARNING!**

**DO NOT USE HYDROCHLORIC ACID**

### ***Air Condenser***

- 1) Disconnect machine.
- 2) Close water faucet.
- 3) Clean condenser using a vacuum cleaner, brush or low pressure air.

### ***Evaporator/Water Tray***

- 1) Switch off the electric panel and place the timer in defrosting position.
- 2) Remove the top cover.
- 3) Place the overflow pipe. Remove the evaporator cover.
- 4) Prepare a solution of 50% phosphoric acid in distilled water. Do not use hydrochlorate acid. Pour slowly this solution in the upper part of the evaporator, until it overflows in the water tray. The mixture is more effective with the water between 35°C. and 40°C.
- 5) Let solution stand for 10 minutes.
- 6) Remove the overflow pipe and wait until the tray is empty. Put again the overflow pipe. (In machines provided with discharge valve should be activated manually).
- 7) Refill the water tray to the maximum level with the same solution. Connect the machine (close faucet) and wait 20 minutes.
- 8) Open faucet, put the timer forward up to the harvest cycle and once the ice has fallen disconnect the machine and put the timer in defrosting position.

**WARNING:\*\*** Discard ice produced during cleaning procedure.

## NOW STARS THE SANITARY CLEANING

- 9) Connect the machine once it has finished entering water, remove the evaporator cover and pour lye (one glass). Wait for 20 minutes.
- 10) Put the timer forward up to defrosting position. Once the ice has fallen, **THROW AWAY THIS ICE** and let the machine produce another complete cycle.

**IMPORTANT:** \*\* Discard ice produced during this procedure.

- 11) Clean and assemble all the components. Verify that the grill is cleaned and that cubes slide properly. Check that any strip gets blocked in the curtain. Check and/or change the water inlet filters.
- 12) Check the adjustments of the cycle thermostat (cubes more or less filled) and that at the end of the cycle the frost is closed to the compressor.
- 13) **CHECK THAT THE NOZZLES ARE PROPERLY PLACED, THAT THE FORMED WATER FANS ARE UNIFORM AND ALL EQUAL.** If necessary, disassemble, clean and put again in the right position.

### ***Cleaning the ice bin.***

- 1) Unplug the machine, turn off water supply, and empty storage bin of ice.
- 2) Wipe with a kitchen cloth soaked in lye and detergent.
- 3) If white lime stains do not vanish, rub with some lemon or vinegar, wait for a few minutes and wipe with the cloth again. Rinse with plenty of water, dry, and run the machine.

### ***Cleaning the outside of the machine***

Follow the same procedure as for the ice bin.

### ***Spray nozzles and connecting pipes***

- 1) Remove the curtain (it can be cleaned with vinegar or phosphoric acid, rinse, clean with lye, rinse)
- 2) Remove the metal grill and clean likewise.
- 3) **PULL UPWARDS THE CONNECTING PIPE. IT HAS BEEN ASSEMBLED BY PRESSING IT INTO PLACE.**
- 4) Disassemble the nozzles and the connecting tube covers and clean them.
- 5) Disassemble and clean the main filter of the production unit. **(IT IS ASSEMBLED BY PRESSING IT INTO PLACE)**

6) Assemble the filter, nozzles and connecting tube.

**ATTENTION:** IT IS ESSENTIAL THAT SPRAY NOZZLES ARE COMPLETELY PERPENDICULAR TO THE CONNECTING TUBES, OTHERWISE THE CUBES AT THE ENDS MAY NOT RECEIVE WATER.

7) Place the grill over the nozzles, with the back slots secure.

8) Install the curtain, ensuring that all of the strips can move freely.

9) Run the machine but DISCARD THE FIRST SET OF ICE CUBES

### ***Cleaning the water inlet filters***

These round wire gasket filters placed on either end of the water hose to mains, often become blocked in the first few days of use, Especially When The Plumbing Installation Is New. Clean them under a jet of water.

### ***Checking for water leaks***

This must be done whenever maintenance is carried out on the machine: check all water connexions, braces, tubes and hoses in order to eliminate leaks and prevent breakages and flooding.

## **SPECIAL ADVICE CONCERNING R-404 REFRIGERANT**

§ R-404 is a mixture of 3 liquid-phase gases. On evaporating, the 3 component gases separate

§ Always use the liquid phase valve (at the end of condenser or accumulator) for refills and purges.

§ When replacing a compressor. wash inside of circuit with a suitable solvent + pump, dry with nitrogen, REPLACE THE DRIER WITH ONE SUITABLE FOR R-404, which must also have ANTI-ACID properties.

§ If you need to add oil, use one which is specific for R-404 (POE). If you are in doubt, contact the machine manufacturer.

§ If there is a leak anywhere in the circuit where R-404 in the GAS phase, and a refill of over 10% is required, then ALL THE GAS IN THE CIRCUIT MUST BE PURGED AND THEN REFILL AS DESCRIBED PREVIOUSLY (LIQUID PHASE VALVE).

## TROUBLESHOOTING

PROBLEM	POSSIBLE CAUSES	SOLUTION
1) None of the electrics work.	A) The machine is not plugged in.	A) Plug the machine.
	B) The line fuse has blown.	B) Replace fuse.
	C) The current line is wrongly connected in the junction box.	C) Check connections.
	D) The cut off micro-switch is faulty or wrongly adjusted.	D) Check, adjust or change.
	E) Safety pressostat faulty.	E) Replace.
2) All the electrics work except compressor.	A) Check switch installed in electrical panel.	A) Select position 1..
	B) Faulty relay .	B) Replace relay.
	C) Faulty "Klixon".	C) Replace Klixon.
	D) Faulty compressor.	D) Replace compressor.
3) All the electrics work but the compressor "klixons"	A) Voltage too low.	A) Check voltage.
	B) Dirty condenser.	B) Clean condenser.
	C) Obstruction in air circulation.	C) Move machine to a correct position.
	D) Fan has broken.	D) Replace fan.
	E) Starter capacitor faulty.	E) Replace condenser.
	F) Fan presostat faulty or wrongly adjusted.	F) Replace or adjust presostat.
	G) Water presostat valve faulty or wrongly adjusted.	G) Replace or adjust.
	H) Cooling water presostat is faulty or badly adjusted.	H) Adjust or change.
J) Non-condensable gases in system.	J) Purge system.	
4) Everything appears to be running correctly but no ice is being made in the evaporator.	A) Unprimed pump.	A) Check overflow, water bin for leaks, water entry valve and prime the pump.
	B) Faulty pump.	B) Replace.
	C) Water does not enter into the bin.	C) Check water entry valve and change if is necessary.
	D) There is water in the gas circuit.	D) Replace the drier, empty the refrigerant (vacuum) and charge new refrigerant.
	E) Water tray is dry.	E) Check overflow pipe and for leaks. Inspect draining valve in machines with automatic cleaning system. Check the buoy valve mechanism in DP90 and DP140.
	F) Freezing system is faulty (dirty condenser, water presostat or entrance valve faulty or wrongly adjusted insufficient refrigerant.	F) Clean condenser, check all the system components: pressostat, water inlet valve, refrigerant charge, etc.

5) Ice cubes form correctly but do not unstick.	A) Faulty hot gas valve or wrongly connected.	A) Verify and change if necessary.
	B) Low water pressure.	B) Increase water pressure if possible. (This can often be done by removing flowmeter on faucet).
	C) Fan pressostat or condensation pressostat too low or faulty.	C) Adjust or replace.
	D) Faulty condensation water inlet valve (water cooled machines without pressostatic)	D) Check and replace.
	E) Faulty water pressostatic valve or too open (water cooled machines with this valve)	E) Adjust, repair or replace.
	F) Room or water temperature below 7°C.	F) Increase the defrost time.
	G) Faulty timer or micros.	G) Check and replace if necessary.
	H) Production time too long. The cubes have flash outside the mold.	H) Adjust by reducing time to the cycle thermostat.
	I) Dirty water inlet filters.	I) Clean filters.
6) Low ice production.	A) Blocked condenser or air access to condenser.	A) Clean condenser; improve air circulation by lifting machine from floor and moving away from walls and hot air sources .
	B) In water-cooled machines:dirty condenser, badly adjusted valve, pressostat, faulty water inlet valve or faulty pressostatic valve.	B) Clean condenser; check, adjust or replace.
	C) Faulty hot gas valve, doesn't close totally.	C) Replace.
	D) Faulty fan or pressostat, faulty inlet cooling water valve.	D) Check fan and re-adjust pressostat or replace.
	E) Refrigerant charge too high or too low.	E) Adjust.
	F) Faulty water inlet valve: leaks and does not close fully.	F) Check and replace.
	G) Inefficient compressor.	G) Replace.
7) Ice cube are so large that they stick together and form a plate of ice	A) Start of cycle thermostat adjusted too low or faulty.	A) Adjust and/or replace.
	B) Timer wheels do not run.	B) Tighten screws on timer.
	C) Faulty timer motor.	C) Check and replace.
	D) Faulty micros on timer or wrongly connected.	D) Verify connections and/or change.
8) Ice cubes are too large.	A) Cycle thermostat adjusted too high.	A) Adjust thermostat.
9) Ice cubes are not completely finished.	A) Cycle thermostat adjusted too low.	A) Adjust thermostat.
	B) Low refrigerant charge.	B) Add refrigerant until there is frost formation 5 cm from the compressor at the end of the cycle.
10) Ice cubes are empty, rough edges and very white.	A) Insufficient water in water pan; unprimed pump.	A) Eliminate water leak.
	B) Obstructed spray nozzles.	B) Clean nozzles.
	C) The curtain strips does not fully close and lose water.	C) Adjust the curtain strips or clean the axle (it may has calcareous impurities that avoid a smooth turn of the strips).
11) Machine doesn't stop even when bin is full.	A) Faulty bin thermostat or wrongly adjusted.	A) Adjust and/or replace.
12) Ice cubes melt in bin.	A) Obstruction in drains (inside the machine or in premises).	A) Unblock.